

(No Model.)

4 Sheets—Sheet 1.

# W. S. HALSEY. LATHE HEAD STOCK.

No. 365,681.

Patented June 28, 1887.

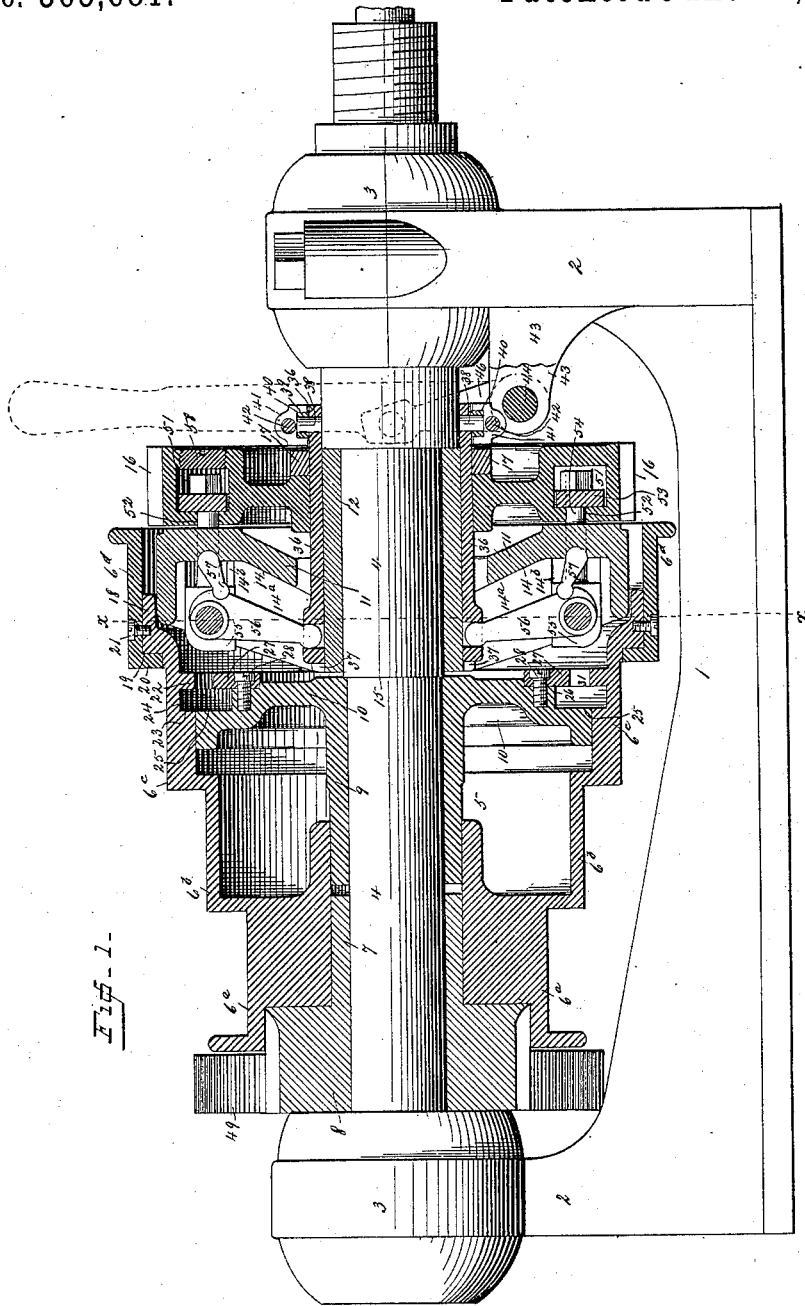

Witnesses  
*E. D. Smith*  
*b. E. Riggles*

Inventor—  
*William S. Halsey*  
 By *A. M. Wooster*  
 Atty.

(No Model.)

4 Sheets—Sheet 2.

W. S. HALSEY.  
LATHE HEAD STOCK.

No. 365,681.

Patented June 28, 1887.

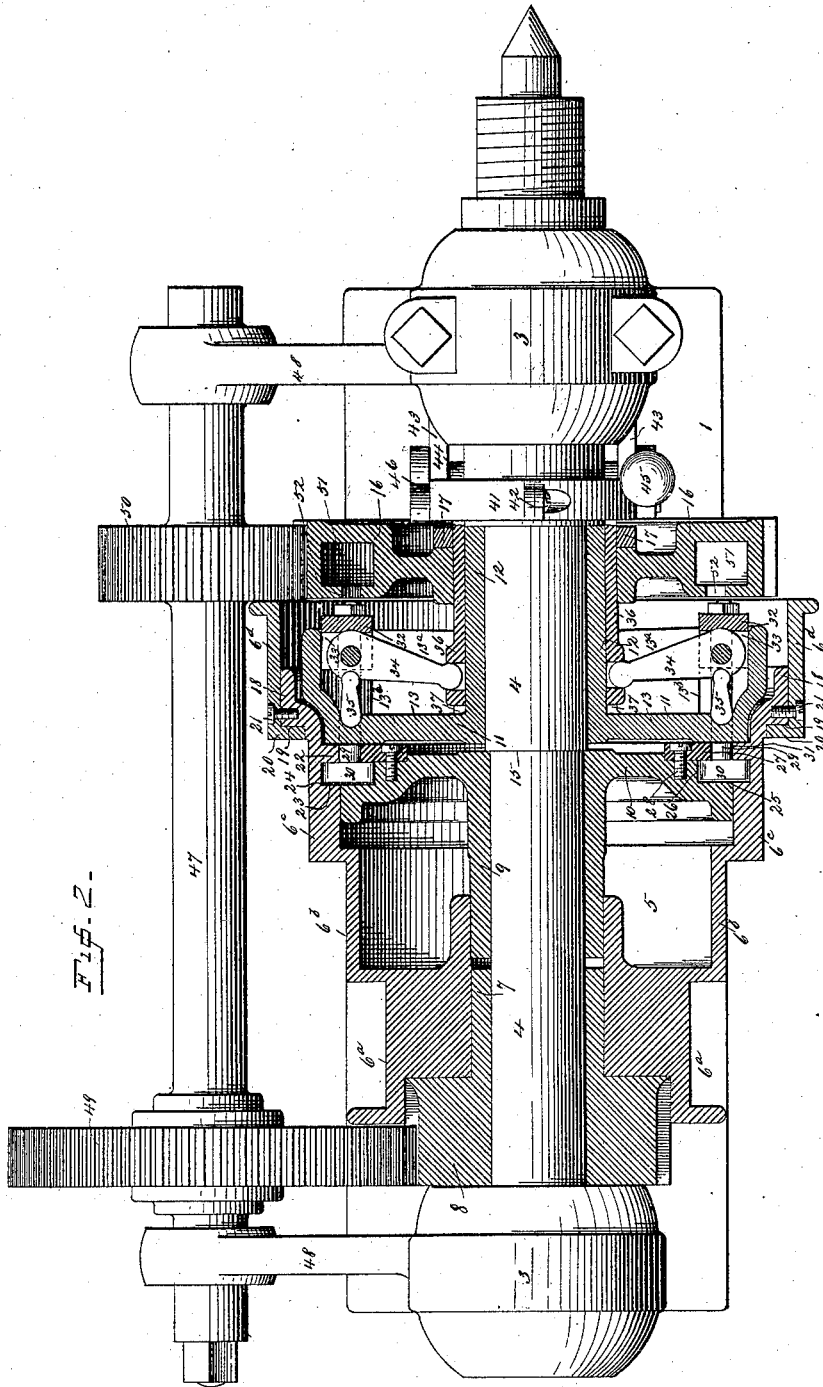

Witnesses.  
E. D. Smith  
E. E. Ruggles

Inventor.  
William S. Halsey  
By A. M. Wooster  
att'y.

(No Model.)

4 Sheets—Sheet 3.

# W. S. HALSEY. LATHE HEAD STOCK.

No. 365,681.

Patented June 28, 1887.

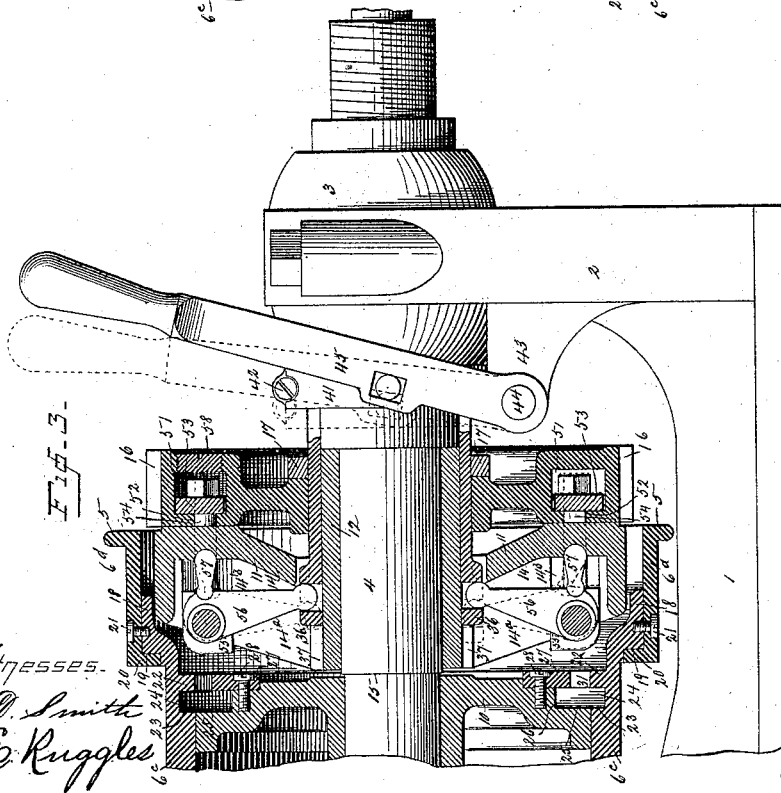
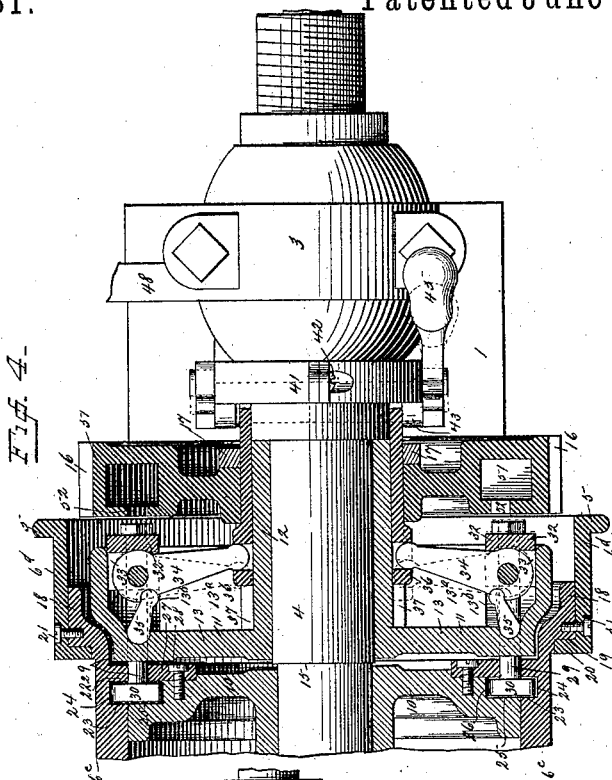

Witnesses:  
*E. D. Smith*  
*C. E. Ruggles*

Inventor:  
*William S. Halsey*  
 By  
*A. M. Wooster*  
 atty.

(No Model.)

4 Sheets—Sheet 4.

W. S. HALSEY.  
LATHE HEAD STOCK.

No. 365,681.

Patented June 28, 1887.

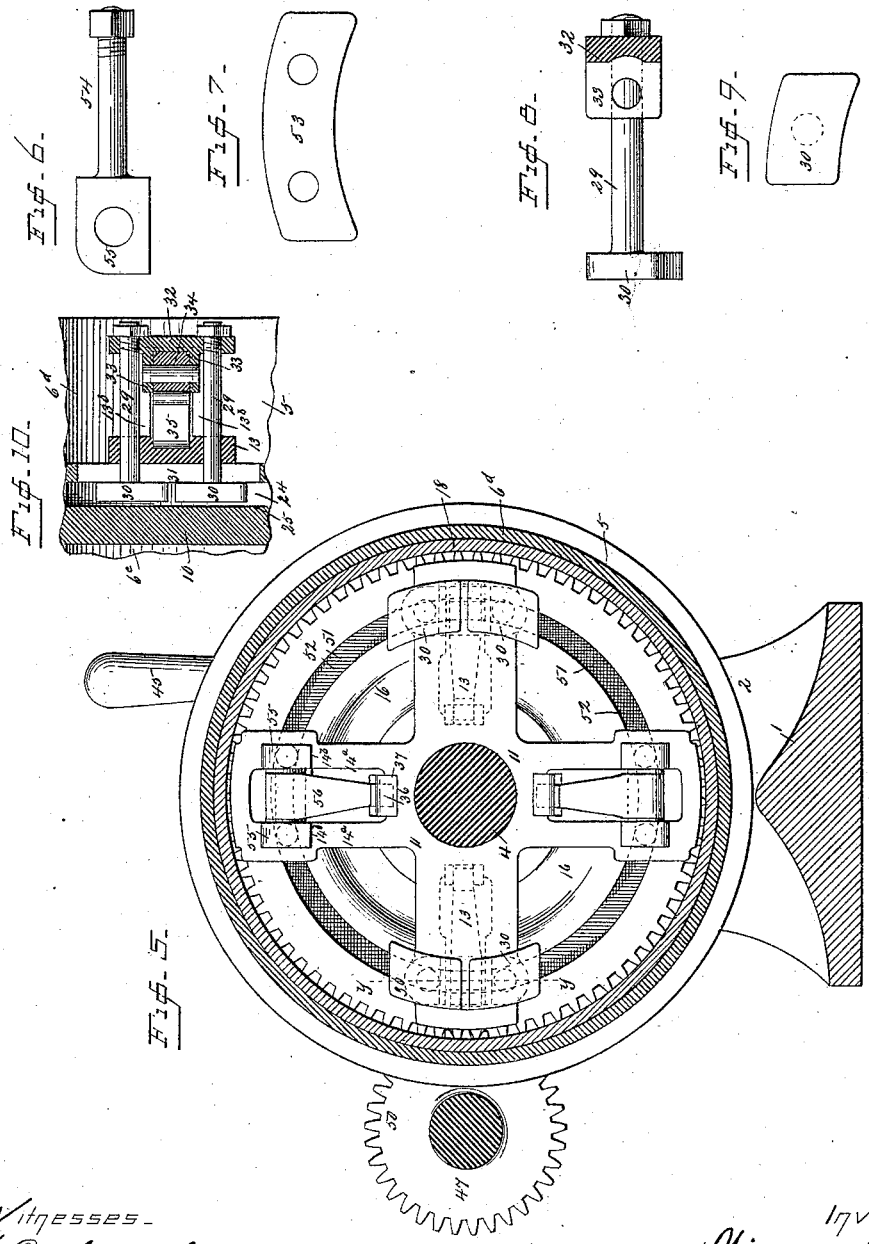

Witnesses -  
E. D. Smith  
C. E. Ruggles.

Inventor -  
William S. Halsey  
By  
A. M. Weston  
att.

# UNITED STATES PATENT OFFICE.

WILLIAM S. HALSEY, OF BRIDGEPORT, CONNECTICUT.

## LATHE HEAD-STOCK.

SPECIFICATION forming part of Letters Patent No. 365,681, dated June 28, 1887.

Application filed February 11, 1887. Serial No. 227,988. (No model.)

### *To all whom it may concern:*

Be it known that I, WILLIAM S. HALSEY, a citizen of the United States, residing at Bridgeport, in the county of Fairfield and State of Connecticut, have invented certain new and useful Improvements in Mechanism for Varying Speed of Head-Stocks; and I do hereby declare the following to be a full, clear, and exact description of the invention, such as will enable others skilled in the art to which it appertains to make and use the same.

My invention has for its objects to produce mechanism of this class which shall be simple in construction, easy to manage, and practically impossible to get out of repair, and whose general mode of operation shall be far superior to anything of this class heretofore produced. With these ends in view I have devised the novel construction of which the following description, in connection with the accompanying drawings, is a specification.

Figure 1 is a side elevation of a head-stock of a lathe embodying my invention, the cone and operative parts of the device being shown in section in position to produce the highest rate of speed; Fig. 2, a plan view of a head-stock of a lathe, the cone and parts within it being shown in section at right angles to the section shown in Fig. 1, the parts being in the same position; Fig. 3, a partial view of the head-stock similar to Fig. 1, but showing the parts in position to produce the lowest rate of speed; Fig. 4, a partial view similar to Fig. 2, the section being at right angles to the section in Fig. 3, the parts being in the position at which the lowest rate of speed is produced; Fig. 5, a transverse section on the line  $xx$  in Fig. 1. Figs. 6 and 7 are detail views illustrating the connections between the spider and the loose gear. Figs. 8 and 9 are detail views illustrating the connections between the spider and the cone; and Fig. 10 is a detail sectional view on the line  $yy$  in Fig. 5, looking toward the left, illustrating these parts in the same position as in Fig. 2.

Similar numbers denote the same parts in all the figures.

1 denotes the frame-work of a head-stock, having standards 2 and bearings 3, of the usual or any preferred construction, and 4 the spindle journaled in said bearings.

5 denotes the cone, which is provided, as usual, with steps  $6^a$   $6^b$   $6^c$   $6^d$ , to receive a belt, whereby different rates of speed are produced. Any preferred number of steps may of course be used, four being shown in the drawings. The cone is free to turn upon the spindle, the bearings therefor consisting of sleeve 7 upon gear 8, and sleeve 9 upon disk 10. The gear and its sleeve and the disk and its sleeve are cast independently of the cone; but both sleeves are rigidly secured to solid portions of the cone by a drive-fit.

11 denotes the spider, which consists of a sleeve, 12, and two pairs of arms projecting radially therefrom, the two arms of each pair being in line with each other, the arms through which connection with the cone is effected being denoted by 13 and the other pair being denoted by 14, as will presently be explained. The sleeve of the spider is rigidly secured to the spindle by a drive-fit, the spider being the only portion of the mechanism that necessarily rotates with the spindle. The diameter of that portion of the spindle upon which sleeve 12 is driven is slightly greater than the portion upon which sleeves 7 and 9 are driven, leaving a slight shoulder, 15, against which the sleeve 9 of the disk rests, so that it is impossible for the cone to have the slightest endwise movement.

16 denotes a loose gear, which is journaled on the sleeve 12 of the spider, being held in place by a collar, 17, driven upon said sleeve.

Beginning at the left, as shown in the drawings, I have indicated the steps of the cone by  $6^a$ ,  $6^b$ ,  $6^c$ , and  $6^d$ . The first three of these steps are formed from a single piece of metal, at the right-hand end of which, as shown in the drawings, is a flange, 18, having a shoulder, 19. Step  $6^d$  is preferably made from a separate piece of metal provided with an angular flange, 20, which rests against shoulder 19. Step  $6^a$  is attached to the flange 18 by screws 21. The purposes of this construction will presently be more fully explained.

22 denotes a circular flange upon the inner side of the cone, which, with shoulder 23, forms the outer portion of a partly-closed circular groove, 24. The back of this groove is formed by shoulder 23 and straight portion 25 of the face of disk 10, said shoulder and the

straight portion or wall being in line with each other, it being of course understood that the disk and cone are made rigid by a drive-fit.

26 denotes a circular shoulder upon disk 10, which forms the inner edge of circular groove 24.

27 denotes a ring, which is secured to the inner face of disk 10 by screws 28. The outer edge of this ring projects outward from the inner edge of groove 24 the same distance that flange 22 projects inward from the outer edge of said groove, so that when said ring is placed in position a perfect T-shaped circular groove is formed, the neck of said groove being indicated by 31.

29 denotes bolts, the heads 30 of which lie in groove 24. It will be observed in Fig. 9 that the bolt-heads are curved slightly to correspond with the curvature of the groove, so as to permit them to slide freely therein. The shanks of the bolts pass through the neck of the groove through each of the arms 13 of the spider, and engage a yoke, 32, as clearly shown in Fig. 10. The bolts preferably pass through the yoke, and are secured by nuts in the usual manner. As already stated, Fig. 10 is a sectional view on the line  $yy$  in Fig. 5, looking toward the left, the bolts being in elevation. The same parts are also clearly shown in Fig. 2, the point of view, however, being entirely different. The yokes 32 slide in ways 13<sup>b</sup> in flanges 13<sup>a</sup> upon arms 13 of the spider, and are provided with inwardly-projecting lugs 33, between which a lever, 34, is pivoted.

35 denotes toggles, which bear respectively against the spider and against lever 34. Both ends of the toggles are rounded, so that they will turn freely in sockets in the lever and spider. The inner ends of levers 34 engage sockets in sliding fingers 36, which move in grooves 37 in the sleeve 12 of the spider. These pins of course pass freely under loose gear 16 and collar 17, both of which bear upon the sleeve of the spider, but not upon the sliding fingers. It will be observed in the figures that the sliding fingers project forward of the loose gear, and are locked by pins 38 to a ring, 39. This ring lies in grooves 40 in half-rings 41, which are secured together by screws 42.

Upon the forward standard of the machine are two brackets, 43. 44 is a shaft journaled in these brackets, which carries at one end an operating-lever, 45, and at the other end an arm, 46. Both arm and lever are pivoted to the sliding rings. It will be seen in the drawings that the arm and operating-lever are not exactly in the same plane with each other.

In order to bring the points of engagement with the half-rings in line with each other, I ordinarily form an offset on the operating-lever, as shown in Fig. 3. In order to illustrate this more clearly, I have dotted both the operating-lever and the arm in Fig. 1. It should be understood in this figure that the operating-lever is at the front and the arm at the back. As already stated, the spider is the only portion of the mechanism fast upon the

spindle, both the cone and the loose gear being capable of rotation independently thereof and of each other. The cone is provided with four steps for a belt, thus giving four different speeds at which the cone may be rotated.

In order to impart the rotation of the cone to the spindle, it is necessary to lock the cone to the spider. The position of the parts when the cone is locked to the spider is clearly shown in Figs. 1 and 2. The operating-lever has been thrown as far as possible toward the left. This forces the sliding fingers inward, carrying the lower ends of levers 34 with them, the effect of which is to straighten the toggles—that is, to move the ends of the toggles resting in the sockets in the levers outward, carrying them from the position shown in Fig. 4 to the position shown in Fig. 2. This acts to force the yokes toward the right, and consequently draws the heads 30 of the bolts, which lie in circular groove 24, against flange 22 and ring 27, thus locking the cone and the spider firmly together, so that the motion of the cone is imparted to the spindle.

47 denotes a shaft journaled in brackets 48, which project from one side of the standards. This shaft carries a gear, 49, which meshes with gear 8 on the spindle, and a gear, 50, which meshes with loose gear 16. It will of course be seen from the relative sizes of gears 49 and 50 that the loose gear 16 must rotate much slower than the cone. The relative speed of the loose gear and cone will of course depend upon the relative number of teeth in the gear-wheels, and may be varied to suit the judgment of the builder. In practice I ordinarily so plan the gears that the cone will rotate six times during each revolution of the loose gear. Suppose, now, that it is desired to produce a slower speed than can be produced by placing the belt on step 6<sup>a</sup>. This result I accomplish by disconnecting the cone and spider and connecting the loose gear with the spider. Figs. 3 and 4 show the position of the parts when the spider is connected with the loose gear. It will be seen that the operating-lever has been thrown as far as possible toward the right, which draws the sliding fingers outward and throws toggles 35 from the position shown in Fig. 2 to that shown in Fig. 4. This releases the grip of heads 30 of the bolts upon the flange and ring, so that the cone will rotate without carrying the spider and spindle with it, heads 30 of the bolts sliding freely in circular groove 24.

The mechanism by which the loose gear is connected with the spider is clearly illustrated in Figs. 1, 3, 5, 6, and 7. The loose gear 16 is provided with a circular groove, 51, having a neck, 52, similar to that formed by flange 22 upon the cone and ring 27 upon the disk. Plates 53 lie in this groove, and bolts 54, extending from these plates, pass through the neck of the groove and through the arms 14 of the spider. These bolts are provided with enlarged flattened heads 55, which slide in ways 14<sup>b</sup> in flanges 14<sup>a</sup> upon arms 14 of the spider,

and levers 56 are pivoted between said heads. The lower ends of levers 56 engage sliding fingers 36 in the same manner as levers 34, which act in connection with the spider and cone. Toggles 57, similar to toggles 35, engage the spider and the levers, both ends of the toggles being rounded and sockets being provided to receive them. The effect of moving the operating-lever from the position shown in dotted lines in Fig. 1 to the position shown in full lines in Fig. 3 is to move toggles 57 from the position shown in Fig. 1 to that shown in Fig. 3, which draws the bolts toward the left, and consequently draws plate 53 against the bottom of groove 51, and draws said gear inward against the spider, as clearly shown in Fig. 3, thus locking the loose gear to the spider and imparting the rotation of said gear to the spindle. It will thus be seen that with the belt upon any one of the steps the movement of the operating-lever from its extreme position toward the left to its extreme position toward the right will disconnect the cone from the spider and connect the spider with the loose gear, so that the spindle will have the movement of said loose gear instead of the cone, thus reducing the speed of the spindle to one sixth (in the present instance) of its former speed without change of belt, and giving eight different speeds to a head-stock constructed as shown in the drawings.

In Fig. 3 I have indicated in dotted lines an intermediate position of the operating-lever. Suppose the lever to be moved to that position from the position shown in Fig. 3. The effect will be to disconnect the spider from the loose gear without connecting it to the cone, so that the cone will receive the rotation imparted to it by the belt, and the loose gear will rotate at one-sixth of the speed of the cone, leaving the spindle disconnected from either cone or loose gear, and consequently stationary. A movement of the operating-lever toward the right connects the spider with the loose gear, and toward the left connects it with the cone.

It is an important feature of my improved construction that while the operating mechanism is perfectly covered and protected access may be readily had to any portion of it. It will be observed in Fig. 1 that the back of the loose gear is provided with a screw-plug, 58, which being removed permits ready access to plates 53, which connect the loose gear with the spider. To remove the nuts from bolts 54 to detach plates 53, it is simply necessary to remove the screw-plug and turn the loose gear until the opening comes in line with the nuts. Should access be desired at any time to the mechanism by which the spider is connected with the cone, it is simply necessary to remove screws 21, which permits step 6<sup>a</sup> to be removed from the cone. Should access be desired to circular groove 24, it is simply necessary to remove screws 28, which connect ring 27 with the disk. It will of course be apparent that the details of construction, the shape of the parts, &c., may be varied to an almost un-

limited extent without departing from the spirit of my invention.

Having thus fully and in detail described my invention, I claim—

1. The spindle, the cone journaled thereon and provided with groove 24, and a spider rigidly secured to said spindle, in combination with bolts 29, having heads lying in said groove, sliding yokes 32, engaged by said bolts, levers 34, pivoted in said yokes, and toggles 35, engaging said levers and the spider whereby the heads of the bolts are caused to engage the groove to lock the cone to the spider.

2. The spindle, the cone journaled thereon and provided with a T-shaped groove, 24, having a neck, 31, and a spider rigidly secured to the spindle, in combination with bolts having heads 30 lying in said groove, sliding yokes engaged by said bolts, levers 34, pivoted in said yokes, toggles engaging said levers and the spider, and sliding fingers, whereby said levers may be operated to connect or disconnect the cone and the spider.

3. In a device for varying the speed of head-stocks, a cone consisting of a number of steps cast in a single piece, gear 8, having a sleeve, 7, disk 10, having a sleeve, 9, flange 18, having shoulder 19, and step 6<sup>a</sup>, secured to said flange and having a flange, 20, resting against shoulder 19.

4. A cone consisting of independent steps for a belt, a flange, 18, and a detachable step, 6<sup>a</sup>, secured to said flange.

5. The combination, with the spindle, spider, and cone, of connecting mechanism, substantially as shown, whereby the spider and cone may be connected or disconnected, and a supplemental step, 6<sup>a</sup>, covering the spider and secured to the cone, whereby, when said step is removed, access may be had to the connecting mechanism.

6. The combination, with a cone having steps for a belt, and a flange, 18, and shoulder 19, of an additional step, 6<sup>a</sup>, made separate therefrom and secured to the flange, said step having an angular flange engaging said shoulder, as and for the purpose set forth.

7. The cone having an internal circular flange, 22, a shoulder, 23, and disk 10, having wall 25 and shoulder 26, in combination with ring 27, secured to said disk opposite flange 22, whereby a circular T-shaped groove is formed, substantially as and for the purpose set forth.

8. The cone having circular groove 24, the spindle, and the spider having ways 13<sup>b</sup>, in combination with yokes 32, adapted to slide in said ways, bolts engaging said yokes and having heads 30 engaging groove 24, toggles 34, and levers 35, whereby said toggles are operated to clamp the bolt-heads against the grooves, thus locking the cone to the spider.

9. The spider having arms 13 in line with each other, said arms having flanges 13<sup>a</sup> and ways 13<sup>b</sup>, in combination with a cone having a T-shaped groove, 24, sliding yokes 32, bolts engaging said yokes, whose heads lie in said

groove, toggles 35, and levers 34, whereby the toggles are operated to engage the bolt-heads with the face of the groove.

10. The spindle, the spider rigidly secured thereto, and loose gear 16, having groove 51, journaled on said shaft, in combination with plates 53, lying in said groove, bolts 54, connected to said plates and having levers 56 pivoted between them, and toggles 57, engaging the spider and said levers, whereby the loose gear is clamped to the spider, as and for the purpose set forth.

11. The spindle, the spider secured thereto and having sleeve 12 and arms 14, and loose gear 16, journaled on said sleeve and provided with a T-shaped groove, 51, in combination with curved plates lying in said groove, bolts connected to said plates and having levers 56 pivoted thereto, and toggles 57, engaging arms 14 and said levers, whereby the loose gear and spider may be clamped together.

12. The spindle, the spider journaled thereon and having arms 14, with flanges 14<sup>a</sup> and ways 14<sup>b</sup>, in combination with loose gear 16, having groove 51, plates lying in said groove, bolts connected to said plates and having heads sliding in said ways, levers 56, pivoted between said bolts, and toggles 57, engaging said levers and the spider, as and for the purpose set forth.

13. The spindle, the spider having sleeves 12, with grooves 37, sliding fingers lying in said grooves, and operating mechanism therefor, in combination with loose gear 16, having grooves 51, plates lying in said grooves, bolts connected to the plates and having heads, levers 56, pivoted between said heads and engaging the sliding fingers, and toggles 57, engaging the levers and the spider, as and for the purpose set forth.

14. The spindle, the spider having arms 14 and sleeve 12, with grooves 37, and fingers 36, sliding in said grooves, in combination with the loose gear, connecting mechanism operated by the sliding fingers for locking the loose gear to arms 14, half-rings 41, connected to the fingers, and an operating lever and arm carried by a shaft and connected to the half-rings, whereby the sliding fingers are operated.

15. The spindle, the spider having arms 13, sleeve 12, with grooves 37, and fingers 36, sliding in said grooves, in combination with a cone, connecting mechanism operated by the sliding fingers for locking the loose gear to arms 13, half-rings 41, connected to the fingers, and an operating lever and arm carried by a shaft and connected to the half-rings, whereby the sliding fingers are operated.

16. The spindle, the spider having arms 13 and 14, sleeve 12, with grooves 37, and fingers 36, sliding in said grooves, in combination with a cone having groove 24, the loose gear having groove 51, and connecting mechanism operated by the sliding fingers, whereby when said fingers are moved in one direction the cone is disconnected from the spindle and the loose gear detached and when moved in the opposite direction the loose gear is connected and the cone detached.

17. The spindle, the spider having arms 13 and 14, the sliding fingers, the cone having groove 24, and the loose gear having groove 51, in combination with plates lying in said grooves, bolts connected to said plates, levers pivoted to said bolts and engaging the sliding fingers, and toggles engaging said levers and the arms of the spider, whereby either cone or loose gear may be connected to the spider, said operation disconnecting the other part.

18. The combination, with the spider, the loose gear, the cone, connecting mechanism, substantially as described, and sliding fingers by which the connecting mechanism is operated, of ring 39, pins connecting said ring with the sliding fingers, half rings 41, having grooves to receive ring 39, and an operating lever and arm carried by the shaft and connected to the half-rings, whereby the sliding fingers may be actuated, as and for the purpose set forth.

19. The spindle, the spider rigidly secured thereto, the loose gear, and the cone, said gear and cone being adapted to rotate independently of the spindle and of each other, and connecting mechanism, substantially as described, in combination with sliding fingers by which the connecting mechanism is operated, and operating mechanism for said fingers, whereby the speed of either cone or loose gear may be imparted to the spindle or said spindle may be disconnected from both.

20. The spindle, the spider having sleeve 12, with grooves 37, in combination with loose gear 16, having groove 51, neck 52, and screw-plug 58, collar 17, engaging said sleeve to hold the gear, fingers sliding in grooves 37 under said gear, a collar, and connecting mechanism operated by said fingers, whereby the spider and gear are connected and disconnected.

In testimony whereof I affix my signature in presence of two witnesses.

WILLIAM S. HALSEY.

Witnesses:

A. M. WOOSTER,  
C. E. RUGGLES.